



Pressure reduction unit – constant flow rates for your process analyzer

Sampling Conditioning Systems (SCS) from Metrohm Process Analytics

HIGHLIGHTS

- **SCS fully controlled** by your Metrohm Process Analyzer
- **High analyzer protection** – avoid sample over pressure causing hardware damage and harmful leaks
- **Better pressure control** – better sample flow to the analyzer, no need for extra pumps
- **Simple installation** straight into the sample line
- **No back-pressure concerns** or «creep» thanks to the pressure relief valve design

Push your analytical analysis with optimal sampling systems

Process operating line pressure is typically reduced by the installation of a pressure relief valve (PRV) to meet the sample inlet valve pressure specification in an online process analyzer. A suitable pressure reducing valve is a valve which takes a high inlet pressure and reduces it to a lower outlet pressure under both flow and no-flow conditions.

Metrohm Process Analytics' pressure reducing valves use a spring and diaphragm combination to control the downstream pressure. Even under no flow conditions this «drop tight» feature is one of the most important criteria for any pressure reducing valves to stop the pressure from «creeping» – a term which is used when an increase in the downstream pressure occurs due to dead pressure against the closed sample inlet valve. A pressure reducing valve which doesn't prevent this «creep» to happen eventually allows the pressure to increase and equal the upstream pressure, which can cause significant problems and damage to the analyzer.

OPERATION PRINCIPLE

The valve uses spring pressure against a diaphragm to open the valve and allow water (or sample) through it. However, when the sample inlet valve in the analyzer is closed, the outlet pressure of the PRV valve forces the diaphragm upward to shut the valve. When the outlet pressure drops below the set point of the valve by opening the sample inlet valve, the spring pressure overcomes the outlet pressure and forces the valve stem downward, opening the valve. As the outlet pressure increases, approaching the desired pressure, the pressure under the diaphragm begins to overcome the spring pressure, forcing the valve stem upward and thereby closing the valve once again.

Setting the downstream pressure to the required set point is simply achieved by turning the adjusting screw or/knob which varies the spring pressure against the diaphragm. And the outlet pressure is verified with the installation of a pressure gauge on the outlet of the PRV.

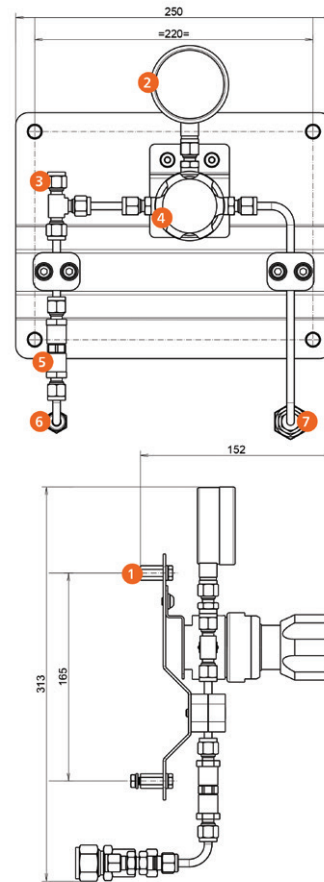

1. 6mm Threaded Wire
2. Pressure Gauge
0 - 1.6 barg
3. Sample to Analyzer
0.5 barg
OD 6mm SS316 Tube
Connector
4. Pressure regulator
0 - 1.6 barg
5. Adjustable relief
valve: 3-50PSI
6. Drain
OD 6mm SS316 Tube
Connector
7. Sample In
OD 14mm SS316 Tube
Connector

Pressure regulator unit front and side view.

SPECIFICATIONS

Instrument	
Dimensions	250 x 313 x 152 mm (W x H x D)
Materials	SS316/PCTFE
Maximum allowable sample temperature*	80 °C
Max. Allowable sample pressure in*	680 kPag (6.8 bar) (other inlet pressures on available 413 bar)
Allowable sample pressure out *	0–160 kPag (0–1,6 bar)

* The total system design must be considered when applying the maximum allowable pressure and temperature ratings.

** The filter element is not included in the filter unit package and must be ordered separately based on specification.